

DAIKIN

PCSAU0739C

SkyAir



360° airflow!!

Air Conditioning Systems
FCQN-KVEA + RQ-LV1A
HEAT PUMP [50Hz]

INVERTER



R-410A

Uniform 360° airflow cassette air conditioner is setting tomorrow's standards.



Option

Accessory required for indoor unit

Wired Remote Controller



"Nav Ease"
BRC1E61

Note: Remote controller cable not included. Cables must be procured locally.

Wireless LCD remote controller

A signal receiver must be added to the indoor unit.











Heat pump **BRC7F632F**

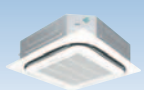

Signal receiver unit
(Installed type)

Wireless remote controller and signal receiver unit are sold as a set.

PRODUCT RANGE

	Series	71	100	125	140
INDOOR UNIT CEILING MOUNTED CASSETTE TYPE <Round Flow> 		 FCQN71KVEA	 FCQN100KVEA	 FCQN125KVEA	 FCQN140KVEA
	INVERTER				
OUTDOOR UNIT		 NEW RQ71LV1A	 RQ100LV1A	 NEW RQ125LV1A	 RQ140LV1A

Avoids uneven temperature and discomfort caused by drafts.

Comfort enhanced by Round Flow!

360 ° airflow

- With uniform temperature distribution



Airflow distribution creates uniform comfort throughout the space

Air movement is gentle with Round Flow

- Enhanced Comfort



360° airflow can maintain comfort even if air discharge speed is lower.

If you raise the set temperature by 1 to 1.5°C in cooling (and lower in heating), and velocity is decreased by 25%, you still obtain the same feeling temperature and comfort.

Adapts easily to the installation space.

- As air flows out from corner outlets, comfort spreads more evenly.

Typical flow patterns There are a total of 23 flow patterns.

All-round flow	3-way flow	L-shaped 2-way flow	Opposite 2-way flow
(E.g., installed in middle of ceiling) 4-way flow also possible.	(E.g., installed near a wall)	(E.g., installed in a corner)	(E.g., installed in a long room)

Note: Whatever the discharge direction, the same type of panel is used. If installing for other than all-round flow, an air discharge outlet sealing member (option) must be used to close each unused outlet.
Operation sound increases when using 2-way or 3-way flow.

Grime prevention and bactericidal coating: Makes cleaning easier.

External panels are treated with a coating that helps to repel dirt.

- To prevent dirt sticking to the external panels, they have been coated with a surface treatment.

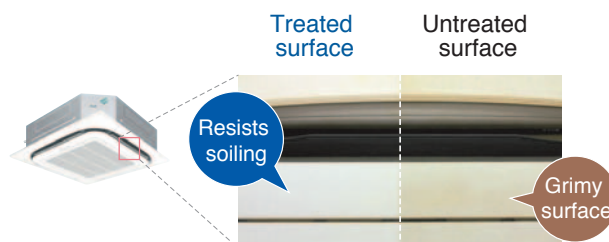

• Condition after exposure to the smoke of 600 cigarettes in 1 m³ enclosed space.

- Bactericidal treatment for drain pan

Anti bacterial treatment, that includes silver ions is used which may assist in preventing the growth of microorganisms that cause smells and clogging.

- Non-flocking horizontal louvres

Dew does not easily form on the non-flocking louvres and may prevent dirt from clinging to them. It is easy to clean.

- Filter has anti-mould and bactericidal treatment

Helps prevents mould and microorganisms growing out of the dust and moisture that adheres to the filters.

Unified square panels

- Panel size is the same for all models, FCQN71-140K. It is easy to maintain a neat appearance when multiple units are installed in the same room.

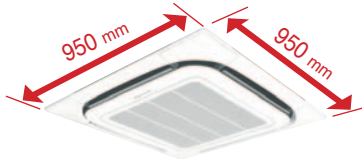

Same for all models

Compact body and quiet operation

Indoor unit	dB(A)	
	High	Low
71K	35	28
100K	43	32
125K	44	34
140K	44	36

Note: Anechoic chamber conversion value, measured according to JIS parameters and criteria. During operation these values are somewhat higher owing to ambient conditions.

Optimal comfort and convenience assured by air discharge modes

Note: Air direction is set to the standard position when the unit is shipped from the factory. The position can be changed from the remote controller.

Air direction	Standard setting	Setting to prevent soiling of ceiling*
Desired situation	Standard setting to prevent draft.	Recommended for shops with light coloured ceilings that must be kept spotless.
Auto-swing	Auto-swing between 15° and 60°	Auto-swing between 25° and 60°
5-levels air direction setting	Settable to 5 different levels between 15° and 60°	Settable to 5 different levels between 25° and 60°
Draft prevention (In heating mode)	At heating startup and thermo OFF, air discharge is automatically set to a near horizontal 25° or 30° to prevent direct exposure to cool air drafts.	
Auto air direction control	The air direction is set automatically to the memorised position of the previous air direction.	

*Closing of the corner discharge outlets is recommended.

Suitable for high ceilings

Even in spaces with high ceilings, a comfortable airflow is carried down to the floor level.

Criteria for ceiling height and number of air discharge outlets

		Number of air discharge outlets used							
		71K				100K-140K			
		All round flow	4-way flow	3-way flow	2-way flow	All round flow	4-way flow	3-way flow	2-way flow
Ceiling height	Standard	2.7 m	3.1 m	3.0 m	3.5 m	3.2 m	3.4 m	3.6 m	4.2 m
	High ceiling ①	3.0 m	3.4 m	3.3 m	3.8 m	3.6 m	3.9 m	4.0 m	4.2 m
	High ceiling ②	3.5 m	4.0 m	3.5 m	—	4.2 m	4.5 m	4.2 m	—

Note: Factory settings are for standard ceiling height and all-round flow. High ceiling settings (1) and (2) are set with the remote controller.

Two selectable temperature-sensors

Both indoor unit and wired remote controller (option (BRC1E61)) contain temperature-sensors. Temperature sensing can be set at the unit or, to further improve comfort level, closer to the target area at the wired remote control. This feature requires initial setting by the installer.

*Temperature-sensor on indoor unit must be used when the air conditioner is controlled from another room.

**Wireless remote controller does not have a temperature-sensor.

Hot start (after defrost)

Switchable fan speed: High/Low

Timer selector

Quick and easy to install

- Just 256 mm high. Installable in tight ceiling spaces (71K)

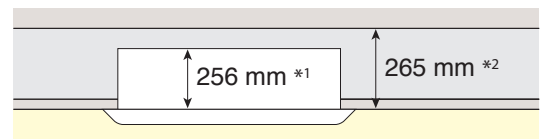

*1 298 mm high with 100K-140K

*2 303 mm high with 100K-140K

Easy height adjustment

Each corner of the unit has an Adjuster Pocket that lets you easily adjust the unit's suspended height.

Note: If the wireless remote control option is installed, a light receptor unit is housed in one of the adjuster pockets.

- All models can be installed without using lifter because of the light weight.

Can be installed in any direction

Since the orientation of the intake grill can be adjusted after installing, the direction of the intake grill lines can be unified when multiple units are installed.

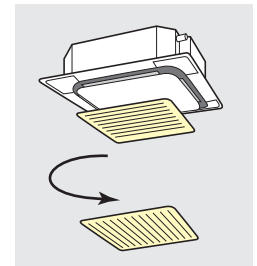

- Drain pump is equipped as standard accessory with 850 mm lift.

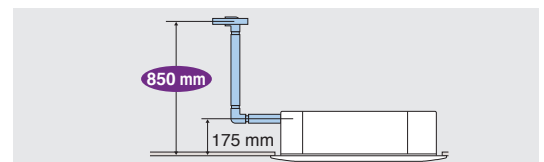

Transparent drain socket



- Easier connection with the centralised control system

- Low gas pressure detection

Easier to maintain

- The condition of the drain pan and drain water can be checked by removing the drain plug and intake grille.

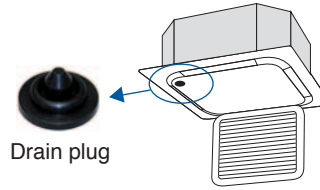

Just open the intake grille!

Options required for specific operating environments

High-efficiency filter

Available in two types: 65% and 90% colorimetry.

Fresh air intake kit

Using this kit, a duct can be fitted to increase the intake of outdoor air.

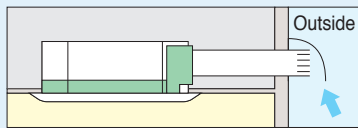

- Note: *Connecting ducts, insect nets, fire dampers, air filters, and other parts should, as required, be procured locally.
 **Outside Air fan interlocked with air conditioning unit is necessary. Optional PCB(KRP1C63)is required for interlocking.
 ***It is recommended that the volume of outdoor air introduced through the kit is limited to 10% of the maximum airflow rate of the indoor unit. Introducing higher quantities will increase the operating sound and may also influence temperature sending.

Panel spacer

Use when only minimal space is available between drop ceilings and ceiling slabs.

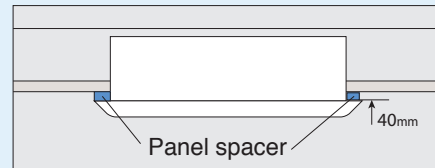

Note: Some ceiling constructions may hinder installation. Contact your Daikin Dealer before installing your unit.

Sealing member of air discharge outlet

Sealing members block air discharge openings not used in 2-way or 3-way blow.

Branch duct (direct-connection round duct)

A round duct can be attached without the need for a chamber. A flanged port for direct connection of a round duct is provided. An existing branch duct chamber can also be fitted (square slit hole).

The units can be installed in the following different ways.

Chamber type

(without T-joint pipe and fan)

KDDP55B160

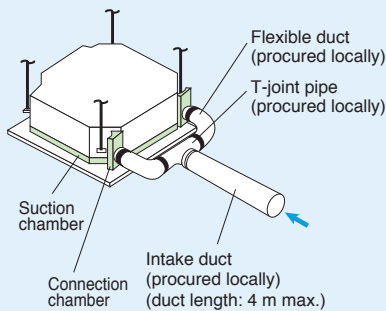

Chamber type

(with T-joint pipe and without fan)

KDDP55B160K

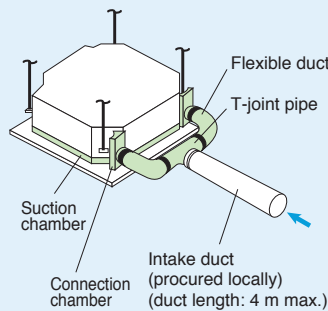

Direct installation type

KDDP55X160

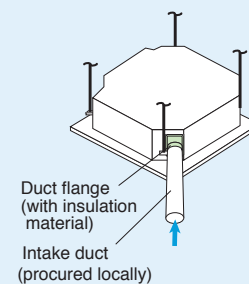

Note: Use of options will increase operating sound.

Compact Outdoor Unit for Round Flow Cassette



NEW RQ71LV1A

NEW RQ100LV1A
NEW RQ125LV1A
NEW RQ140LV1A

Easy installation and maintenance

Pre charged for up to 30 metres

If refrigerant piping length does not exceed 30 m, there is no need for on-site gas charging.

50 m piping length

Allowed refrigerant pipe length and level difference

	Pre charged *1	Max. length	Max. level difference
RQ71L	30 m	50 m (Equivalent length 70 m)	30 m
RQ100L	30 m	50 m (Equivalent length 70 m)	30 m
RQ125L	30 m	50 m (Equivalent length 70 m)	30 m
RQ140L	30 m	50 m (Equivalent length 70 m)	30 m

Note: *1 Additional refrigerant charging is required if the refrigerant pipe is longer than the length.

4-direction piping offers greater layout freedom

The outer panel for the piping connection part of the front, right side and backside can be removed and is easier for post-installation piping work.

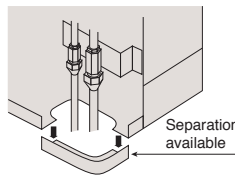

Facilitates pump down (Refrigerant recovery function)

A pump-down switch is provided to make it easier to collect refrigerant if the unit is to be moved or layout modified.

*Pump-down function is available for pre-charged refrigerant amount.

Low gas level detection function

Effective gas monitoring reduces the labor required for operation, maintenance, and repairs.

Durability

As the bottom frame is subject to corrosion, a corrosion-proof galvarium steel plate is adopted to enhance the durability.

Heat exchange fins are provided with anti-corrosion treatment

Construction

- Non-treated fin ← Aluminium
- Anti corrosion treated heat exchangers ← Hydrophilic film
- ← Aluminium
- ← Corrosion resistant acrylic resin

A coating of 40 μm or more protects the outside unit from exposure to rain and snow.

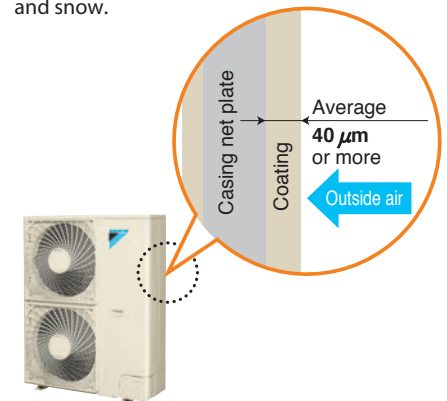

Compact and light weight

Easy centralised installation with the module oriented design

	71L	100/125/140L
Height(mm)	770	1,170
Width(mm)	900	
Depth(mm)	320	
Weight(kg)	68	98

Operation range

Suited for year-round cooling applications

Cooling is efficient even in winter when indoor temperatures are higher than those outside, such as in underground public spaces or offices with many computers.

Wide operation range

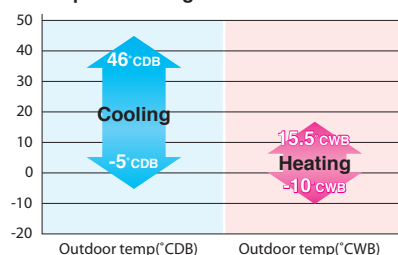

Demand Control Function

The maximum capacity is maintained within a set level of power consumption, which makes it possible to keep a comfortable and effective demand control.

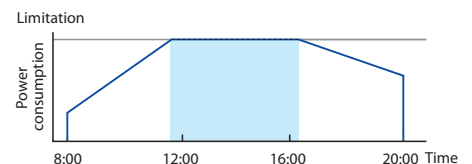

* Required for KRP58M51 (Option)

Night time quiet operation function

The Automatic night quiet mode will initiate 8 hours after the peak temperature is reached in the daytime, and normal operation will resume 10 hours after that.

★ Reducing noise will reduce capacity slightly.

	Sound level ¹ (dB(A))	
	Rated ²	Night Quiet Mode
RQ71L	49	45
RQ100L	51	46
RQ125L	51	46
RQ140L	52	47

Note : ¹Anechoic chamber conversion value, measured according to JIS parameters and criteria. During operation these values are somewhat higher owing to ambient conditions. ²Value when cooling. Value will differ when heating.

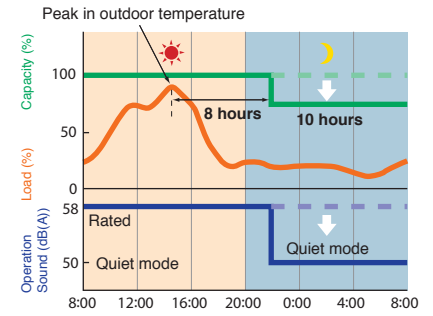

Technology for efficient and quiet operation.

1 Scroll compressor (RQ100/125/140LV1A)

Smooth running, minimal vibration, low operating noise

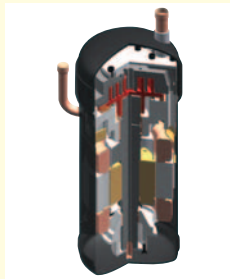

RQ71LV1A

>> Swing compressor

Energy savings is realised, eliminating the friction and the leakage of refrigerant gas.

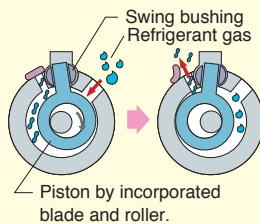

RQ100LV1A/125LV1A/140LV1A

>> The structural scroll

Sucked gas is compressed in the scrolling part before the heated motor, so that the machine compress the non-expanded gas, resulting high efficiency compression.

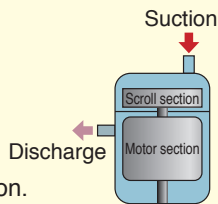

2 Smooth Air Inlet Bell Mouth and Aero Spiral Fan

These two features work to reduce noise. Guides are added to the bell mouth intake to reduce turbulence in the airflow generated by fan suction. The Aero Spiral Fan features fan blades with the bent blade edges, further reducing turbulence.



With the bent blade edge



Without the bent blade edge



Escaping eddies are sucked in by the bent blade edges, reducing overall turbulence.

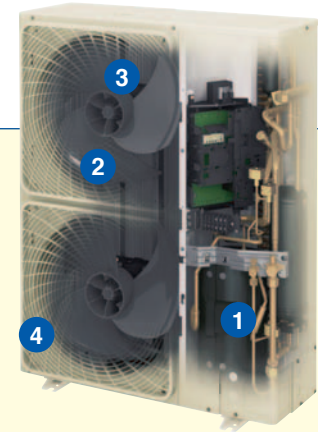

3 DC fan motor

Efficiency improved in all areas compared to conventional AC motors, especially at low speeds.

DC fan motor structure

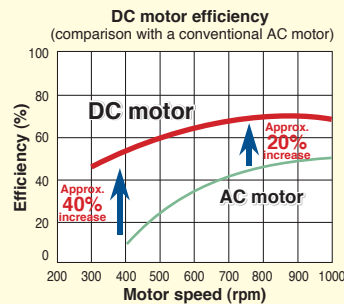

Note: Data are based on studies conducted under controlled conditions at a Daikin laboratory.

4 Super Aero Grille

The grill is shaped to match the direction the fan blows in order to tame the wind turbulence.



Easy-to-read LCD remote controller allows various can control multiple indoor units.

Remote controller options are shown on the page introducing each indoor unit model.

Wired Remote Controller "Nav Ease"

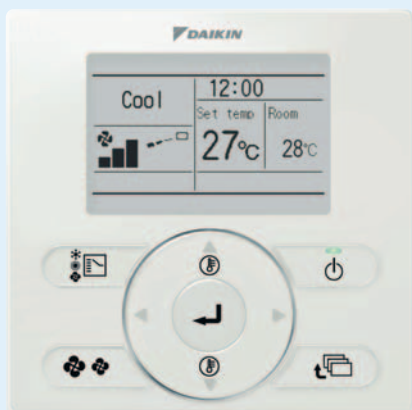

BRC1E61

Clear display, Simple operation.

This advanced, yet simple and modern remote controller, makes operation easier by simply following the indications on the new remote controller.

Clear Display

Dot matrix display

A combination of fine dots enables various icons and texts to be displayed smoothly. Large text display improves readability.

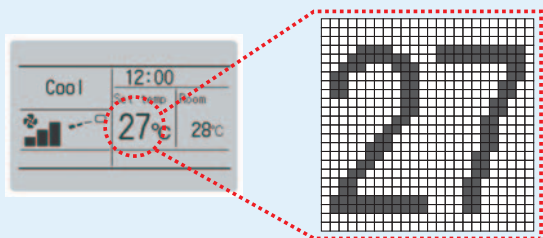

Backlight display

Equipped backlight helps operating in dark rooms.

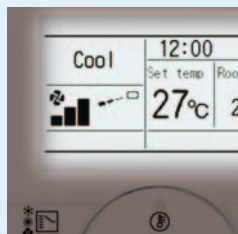

Simple operation

Large buttons and arrow keys



Large buttons and arrows keys for easy operation. Basic settings such as fan speed and temperature can be intuitively operated. For other settings just select the function from the menu list.



Guide on display

The display gives an explanation of each setting for easy operation.

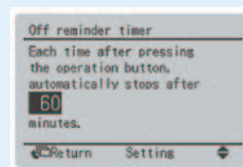
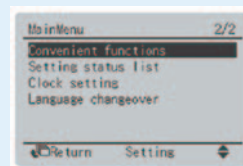

Available in 10 languages

Multilingual display

Display is available in 10 languages.

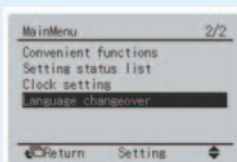

us system control configurations and

Weekly schedule timer

The weekly schedule timer can be easily programmed. Up to 5 ON/OFF settings can be set per day for each day of the week.

Monday	Time	Operation
	00:00	22°C
	12:00	OFF
	14:00	20°C-26°C
	18:00	OFF
	21:00	26°C

Any daily programs set can be replicated to occur on any other day by simply using the copy function.

The temperature can be set for the ON setting, this makes it possible to change the set temperature automatically at a specific time during operation.

Example of setting for an office (in summer)

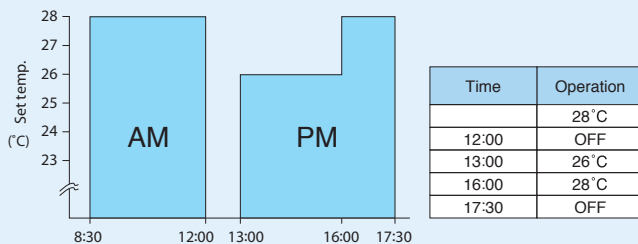

Other Features

Off reminder timer

The off timer becomes effective automatically every time the operation button is pushed. Can preset the operation period from 30 to 180 minutes in 10 minute units.

Error code / model name display

If an error occurs, the error code, model name and contact address are displayed.

*Contact address need to be registered at the installation.

*Model name or model code will be displayed depends on the model.

LCD wireless remote controller



Wireless remote controller



Signal receiver unit
(For ceiling mounted cassette type)

BRC7F632F



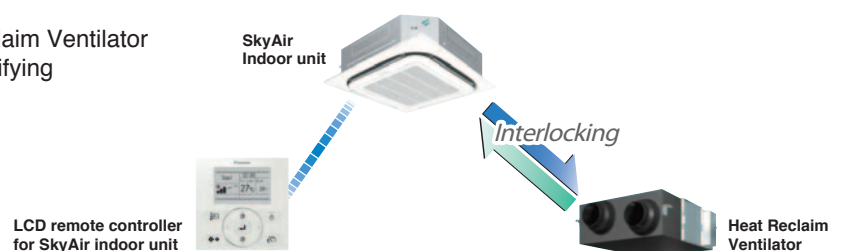

- The wireless remote controller is supplied in a set with a signal receiver.
- Signal receiver unit is contained inside decoration panel or indoor unit.
- Shape of signal receiver unit differs according to the indoor unit.

Note: The signal receiver unit shown in the photograph is for mounting inside the decoration panel of the ceiling mounted cassette type.

SkyAir shares common control with the Heat Reclaim Ventilator and other Daikin air-conditioning units, thus simplifying interlocking operations.

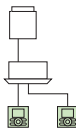
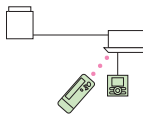
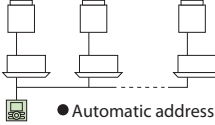
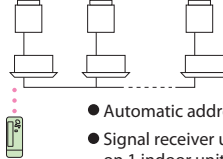

Simple system provides a diverse assortment of control modes.

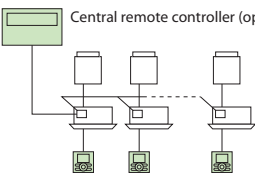
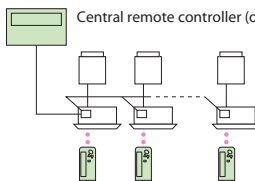
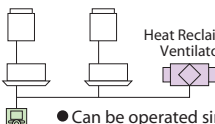
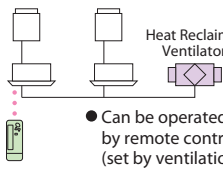
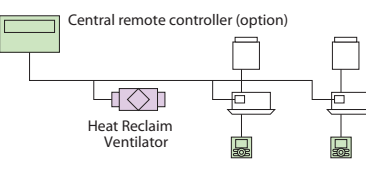
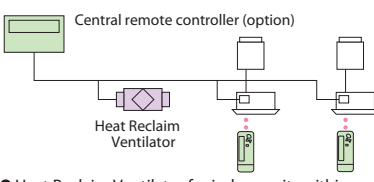
	Control pattern	Wired remote controller	Wireless remote controller
Control by 1 remote controller	(Basic system)	 <ul style="list-style-type: none"> ● Non-polar, double-core (max. wiring length 500 m) 	 <ul style="list-style-type: none"> ● Signal receiver unit installed on indoor unit
Control by 2 remote controllers	For control from 2 locations such as in room and control room, exits, etc.	 <ul style="list-style-type: none"> ● Connects 2 wired remote controllers 	 <ul style="list-style-type: none"> ● Not possible
Group control	For simultaneous control of up to 16 indoor units.	 <ul style="list-style-type: none"> ● Automatic address setting function 	 <ul style="list-style-type: none"> ● Automatic address setting function ● Signal receiver unit installed on 1 indoor unit
Control by external command	Operation and surveillance is carried out using the contact signal from the operation control box in the building surveillance (security) room.	 <ul style="list-style-type: none"> ● Optional wiring adaptor for electrical appendices is necessary 	 <ul style="list-style-type: none"> ● Optional wiring adaptor for electrical appendices is necessary
Centralised remote control	Centralised control of up to 64 indoor groups from remote location up to 1 kilometer away.	 <ul style="list-style-type: none"> ● Optional SkyAir series interface adaptor required. 	 <ul style="list-style-type: none"> ● Optional SkyAir series interface adaptor required.
Interlock control with Heat Reclaim Ventilator	Link by remote controller group control.	 <ul style="list-style-type: none"> ● Can be operated simultaneously or independently by remote controller (set by ventilation mode) 	 <ul style="list-style-type: none"> ● Can be operated simultaneously by remote controller (set by ventilation mode)
	Zone link control by centralised control.	 <ul style="list-style-type: none"> ● Heat Reclaim Ventilator for indoor units within a zone are operated by interlocking. Can also be operated independently by remote controller. 	 <ul style="list-style-type: none"> ● Heat Reclaim Ventilator for indoor units within a zone are operated by interlocking

Note: When a wireless remote controller is used, remote control by two remote controllers is not possible.

Easily adaptable to large-scale, high-function, centralised remote control system.

Central remote controller

DCS302CA61 (Option)



Centralised control, with a setting as simple as it is with a standard remote controller, of up to 64 groups (1,024 indoor units) is possible.

Unified on/off controller

DCS301BA61 (Option)



Centralised control of on/off by group or all at once for up to 256 indoor units.

Schedule timer

DST301BA61 (Option)



Unified control of weekly schedule for up to 1,024 indoor units. Schedule timer sets on/off time in 1 minute units to be executed twice a day for a week at a time.

Intelligent Controller

DCS601C51 (Option)



With its high functionality, the full colour "all-in-one" graphic controller facilitates management of SkyAir System in a variety of ways.

Interface adaptor for SkyAir series

DTA112BA51 (Option)

Enables centralised control via connection to a high-speed, DIII-NET communication system, adopted for the Daikin VRV system. Necessary for interface adaptor for SkyAir series with the central remote control units shown at above.

● The interface adaptor for the SkyAir series is optional except for the ceiling mounted cassette type.

Abundance of features that provide comfortable air-conditioning in stores and offices.

Comfort

Auto-swing

Delivers comfortable air-conditioning to all areas, near to and far from the air-conditioner.

■ The air flow direction can be fixed at your desired angle by the remote controller.

Swing pattern selection

(standard, ceiling soiling prevention)

You can freely set 2 air discharge settings by remote controller.

- (1) Air direction in standard setting
- (2) Air direction in ceiling soiling prevention setting

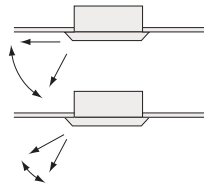

Draft prevention function (heating)

To prevent cold air drafts, automatically adjusts airflow to near horizontal position when heating initially starts or when the thermostat turns off.

Switchable fan speed

High setting provides maximum reach while low setting minimises drafts.

Programme "Dry" with a humidity sensor

Dehumidification is a microprocessor controlled to prevent abrupt and uncomfortable changes in air temperature. Useful for reducing uncomfortable humidity without uncomfortable cooling of the room.

High-ceiling application

Delivers air-conditioning comfort all the way down to the floor in air-conditioning zones with high ceilings.

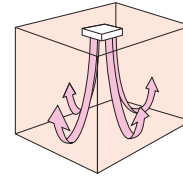

Note: When units are installed on high ceilings, depending on the model, various restrictions concerning maximum height, air discharge direction, and choice of options may apply.

Two selectable temperature-sensors

Temperature-sensors are included in the indoor unit and optional wired remote controller. Temperature sensing closer to the target area is possible to further increase the comfort level.

- Use the temperature-sensor in the indoor unit when controlling air conditioning from another room.

Note: Wireless remote controllers have no temperature-sensor.

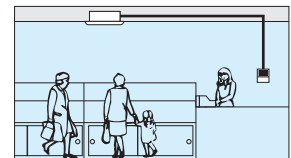

Hot start (after defrost)

Cold air flow is avoided when heating operation starts or when switching to heat after defrosting.

Year-round cooling applicable

Efficient cooling even in winter when the indoor temperatures are higher than those outside, such as in underground public spaces or offices with many computers.

Night quiet operation

The Automatic night quiet mode will initiate 8 hours after the peak temperature is reached in the daytime, and normal operation will resume 10 hours after that.

Timer selector

Operation starts when the preset time of the ON timer elapses and stops when the preset time of the OFF timer elapses.

Weekly schedule timer

Up to five operation ON/OFF settings can be programmed per day for each day of the week. Not only can the time be set for the operation ON setting, but also the temperature.

Cleanliness

Anti-bacterial air filter

The Air filter has a anti-bacterial treatment to help prevent the growth of bacteria and mould on it.

Silver ion anti-bacterial drain pan

Drain pan has silver ion anti-bacterial treatment to help prevent the growth of bacteria and mould.

Work and Servicing

■ Drain pump mechanism

Steeper gradient realises more efficient condensate drainage. High-lift is especially useful for long lengths of drain piping.

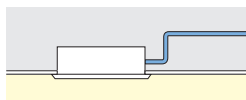

■ Pre charged for up to 30 metres

If the refrigerant piping length does not exceed 30 m, there is no need for on-site gas charging.

■ Ceiling soiling prevention function

Daikin's innovative air discharge mechanism keeps airflow away from the ceiling. Ceiling cleaning is less frequently required.

■ Filter sign

The filter sign warns you when it is time to clean the filter.

*When using a wired remote controller the sign is displayed in the LCD. When using a wireless remote controller the filter sign lamp illuminates on the signal receiver unit.

■ Low gas pressure detection

Insufficient gas charging is normally hard to detect. During post-installation trials and regular inspection procedures, the refrigerant level is monitored by a microprocessor to maintain proper gas pressure. Reliability is assured and maintenance and inspection can be carried out more quickly.

■ Emergency operation

If there is a malfunction elsewhere in the system, the fan or compressor can still be operated.

■ Self diagnosis function

The operating parameters of indoor and outdoor units, and sensor data at critical locations throughout the system, are constantly monitored using a microcomputer. To facilitate a quick response in the event of a malfunction, a message appears on the LCD of the remote controller and an LED on the unit illuminates.

Control features

■ Auto-restart

If there is a power outage while the equipment is operating, operations will restart in the same mode as before the power cut when electricity is restored.

■ Auto cool/heat change-over (Heat pump only)

Detects difference in preset temperature and actual room temperature and automatically switches to cooling or heating accordingly.

■ Control by 2 remote controllers

Using 2 remote controllers you can operate the equipment locally or from a remote location.

Note: When a wireless remote controller is used, remote control by two remote controllers is not possible.

■ Group control by 1 remote controller

You can turn up to 16 indoor units on/off with a single remote controller. (When using connected indoor units, the settings must all be the same and on/off will be simultaneous.)

■ External command control

Operation and surveillance is carried out using the contact signal from the operation control box in the building surveillance (security) room.

*Required for KRP58M51 (Option)

■ Central remote control

An optional central remote controller enables centralised control of up to 1024 indoor units (64 groups) from up to 1 kilometer away.

■ Interlock control

Enables interlocking control with external equipment such as Heat Reclaim Ventilator.

Options

■ High-efficiency filter unit

Two types are available: 65% and 90% colorimetry.

■ Fresh-air intake kit

You can provide air-conditioning with fresh air from outside. Convenient for places where a ventilation fan cannot be installed.

Note: *Connecting ducts, insect nets, fire dampers, air filters, and other parts should, as required, be procured locally.

**Outside Air fan interlocked with air conditioning unit is necessary. Optional PCB(KRP1C63) is required for interlocking.

***It is recommended that the volume of outdoor air introduced through the kit is limited to 10% of the maximum airflow rate of the indoor unit. Introducing higher quantities will increase the operating noise and may also influence temperature sending.

Others

■ Anti corrosion treated heat exchangers

To achieve increased durability by improved resistance to salt corrosion and atmospheric pollution, coated Anti corrosion treated heat exchangers (with special acryl pretreatment) are used for the heat exchanger of the outdoor unit. In high corrosive areas, regular maintenance needs to be carried out.

SPECIFICATIONS

CEILING MOUNTED CASSETTE TYPE

			71	100	125	140	
Model Name	Indoor unit		FCQN71KVEA	FCQN100KVEA	FCQN125KVEA	FCQN140KVEA	
	Outdoor unit		RQ71LV1A	RQ100LV1A	RQ125LV1A	RQ140LV1A	
Power supply			1 Phase, 220-240 V, 50 Hz				
Cooling capacity rated (Min. - Max.) ¹		kW	7.1 (3.6-7.1)	10.0 (5.0-10.0)	12.5 (6.3-12.5)	13.6 (6.8-13.6)	
Heating capacity rated (Min. - Max.) ²		kW	8.0 (4.0-8.0)	11.2 (5.6-11.2)	14.0 (7.0-14.0)	16.0 (8.0-16.0)	
Power consumption	Cooling ¹	kW	2.09	3.09	4.16	4.54	
	Heating ²	kW	2.21	3.20	4.02	5.00	
AEER	Cooling ¹		3.24	3.16	2.96	2.95	
ACOP	Heating ²		3.43	3.40	3.40	3.14	
Indoor unit	Colour	Unit	Fresh white				
		Decoration panel	Fresh white				
	Airflow rate (H/L)	ℓ/s	350/225	533/333	550/375	550/375	
		m ³ /min	21/13.5	32/20	33/22.5	33/22.5	
	Sound level (H/L) ³	dB(A)	35/28	43/32	44/34	44/36	
	Sound power (H/L) ⁴	dB(A)	53/46	60/50	61/52	61/53	
	Dimensions (H×W×D)	Unit	mm	256×840×840	298×840×840	298×840×840	298×840×840
		Decoration panel	mm	50×950×950	50×950×950	50×950×950	50×950×950
	Machine weight	Unit	kg	21	24	24	24
		Decoration panel	kg	5.5	5.5	5.5	5.5
Certified Indoor Operation Range	Cooling	°CWB	14 to 25				
	Heating	°CDB	15 to 27				
Outdoor unit	Colour		Ivory white				
	Compressor	Type	Hermetically sealed swing type	Hermetically sealed scroll type			
		Motor output	kW	1.7	1.9	2.4	3.1
	Refrigerant charge (R-410A)	kg	2.75 (Charged for 30 m)	3.7 (Charged for 30 m)	3.7 (Charged for 30 m)	3.7 (Charged for 30 m)	
	Sound level	Cooling/Heating ³	dB(A)	49/51	51/55	51/53	52/54
		Night quiet mode	dB(A)	45	46	46	47
	Sound power ⁴	dB(A)	67	67	—	—	
	Dimensions (H×W×D)	mm	770×900×320	1,170×900×320	1,170×900×320	1,170×900×320	
	Machine weight	kg	68	98	98	98	
	Certified Outdoor Operation Range	Cooling	°CDB	-5 to 46			
Heating		°CWB	-10 to 15.5				
Piping connections	Liquid (Flare)	mm	ø9.5	ø9.5	ø9.5	ø9.5	
	Gas (Flare)	mm	ø15.9	ø15.9	ø15.9	ø15.9	
	Drain	Indoor unit	mm	I.Dø25×O.Dø32	I.Dø25×O.Dø32	I.Dø25×O.Dø32	I.Dø25×O.Dø32
	Outdoor unit	mm	ø26.0 (Hole)	ø26.0 (Hole)	ø26.0 (Hole)	ø26.0 (Hole)	
Max. interunit piping length	m	50 (Equivalent length 70)					
Max. installation level difference	m	30					
Heat insulation		Both liquid and gas piping					

Note :

¹Cooling capacities are based on the following conditions:

Indoor temp., 27°CDB, 19.0°CWB; outdoor temp. 35°CDB Equiv. refrigeration piping, 7.5 m (horizontal).

²Heating capacities are based on the following conditions:

Indoor temp., 20°CDB, outdoor temp., 7°CDB, 6°CWB. Equiv. refrigeration piping, 7.5 m (horizontal)

³Anechoic chamber conversion value, measured according to JIS parameters and criteria. During operation these values are somewhat higher owing to ambient conditions.

⁴Numerical values are according to ISO 3741:1999.

OPTIONS

Indoor unit

CEILING MOUNTED CASSETTE TYPE

Name of option	Remark	Kit name			
		FCQN71KVEA	FCQN100KVEA	FCQN125KVEA	FCQN140KVEA
Decoration panel		BYCP125K-W1			
Sealing member of air discharge outlet		KDBH55K160F			
Panel spacer		KDBP55H160FA			
Fresh air intake kit ¹	Chamber type	Without the T-joint pipe and fan	KDDP55B160		
		With the T-joint pipe, without fan	KDDP55B160K		
	Direct installation type		KDDP55X160		
Chamber connection kit ²		KKSJ55KA160			
Insulation kit for high humidity		KDTP55K80		KDTP55K160	
High-efficiency filter	(Colorimetric method 65%)	KAFP55B80		KAFP55B160	
	(Colorimetric method 90%)	KAFP557B80		KAFP557B160	
Replacement high-efficiency filter	(Colorimetric method 65%)	KAFP552B80		KAFP552B160	
	(Colorimetric method 90%)	KAFP553B80		KAFP553B160	
Filter chamber		KDDFP55B160			
Branch duct chamber		KDJP55B80		KDJP55B160	
Remote controller	Wireless type	BRC7F632F			
	Wired type ³ "Nav Ease"	BRC1E61			
Central remote controller ⁴		DCS302CA61			
Unified ON/OFF controller ⁴		DCS301BA61			
Schedule timer ⁴		DST301BA61			
Intelligent Touch Controller ⁴		DCS601C51			
Adaptor for wiring ⁵		KRP1C63			
Group control adaptor ⁵		KRP4AA53			
Installation box for adaptor PCB		KRP1H98			
Remote sensor (for indoor temperature)		KRCS01-4B			

Note: ¹Refer to page 4 for the details.

²Required for installing high-efficiency filter or ultra long-life filter.

³Wiring for wired remote controller to be procured locally.

⁴This type of indoor units is equipped with the interface adaptor for SkyAir series. DTA112BA51 is unnecessary.

⁵Installation box for adaptor PCB (KRP1H98) is necessary.

OPTIONS

Round flow type: List of optional parts required to achieve different flow patterns

For each flow pattern – all round, 4-way, 3-way, 2-way, branch duct connection – the compatibility of each independently installed option (shown in the column on the left) to accessory options (listed across the top of each table) is shown in the cells where the relevant row and column intersect. A circle (O) indicates compatibility, and a cross (X) indicates incompatibility. Any options not shown below are not suitable for independent or accessory installation.

All-round flow 4-way flow

Independently installable optional parts		Optional accessory parts					
		Panel spacer ¹	Wireless remote controller	Fresh air intake kit (Chamber type) ^{1,2}	Fresh air intake kit (direct mount)	High-humidity operation kit	High-efficiency filter ²
Panel/grille related	Panel spacer ¹		O	O	O	X	O
Operation control related	Wireless remote controller	O		O	O	O	O
Auxiliary function related	Fresh air intake kit (Chamber type) ^{1,2}	O	O		X	X	O
	Fresh air intake kit (direct mount)	O	O	X		O	O
	High-humidity operation kit	X	O	X	O		X
Filter related	High-efficiency filter ²	O	O	O	O	X	

3-way flow 2-way flow

Independently installable optional parts		Optional accessory parts					
		Panel spacer ¹	Wireless remote controller	Fresh air intake kit (Chamber type) ^{1,2}	Fresh air intake kit (direct mount)	High-humidity operation kit	High-efficiency filter ²
Panel/grille related	Panel spacer ¹		O ³	O ³	O ³	X	X
Operation control related	Wireless remote controller	O ³		O	O	O	X
Auxiliary function related	Fresh air intake kit (Chamber type) ^{1,2}	O ³	O		X	X	X
	Fresh air intake kit (direct mount)	O ³	O	X		O	X
	High-humidity operation kit	X	O	X	O		X

Branch duct connection

Independently installable optional parts		Optional accessory parts					
		Panel spacer ¹	Wireless remote controller	Fresh air intake kit (Chamber type) ^{1,2}	Fresh air intake kit (direct mount)	High-humidity operation kit	High-efficiency filter ²
Branch duct ¹ (Chamber type) (Round duct type)	1-way branch / unit 3-way flow	O	O	O	O ⁴	X	X
	2-way branch / unit 2-way flow	X	O	O	O ⁴	X	X
	1-way branch / unit 2-way flow	X	O	O	O ⁴	X	X

¹In some cases, depending on how the unit is embedded in the ceiling, use of branch ducts and fresh air intake kits may not be possible. Before starting installation work make sure to check whether or not joint installation is possible. In particular, ensure that the lower fixing position caused by the addition of panel spacers is acceptable.

²Use a chamber connection kit if two different types of optional chamber are used together. In this case, the fresh air intake kit must be installed in the upper position.

³It is not possible to use panel spacers in a 2-way flow installation.

⁴It is not possible to install a branch duct on the same side to which a fresh air intake kit (direct mount) is installed.

Outdoor unit

Name of option	Kit name			
	RQ71LV1A	RQ100LV1A	RQ125LV1A	RQ140LV1A
Central drain plug	KKPJ5F180			
Wire fixture for preventing overturning	K-KYZP15C			
Fixture for preventing overturning	KPT-60B160			
Demand adaptor	KRP58M51			

DIMENSIONS (Unit: mm)

CEILING MOUNTED CASSETTE TYPE

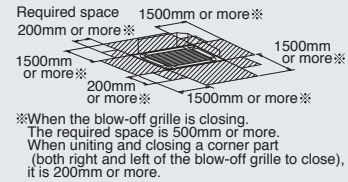
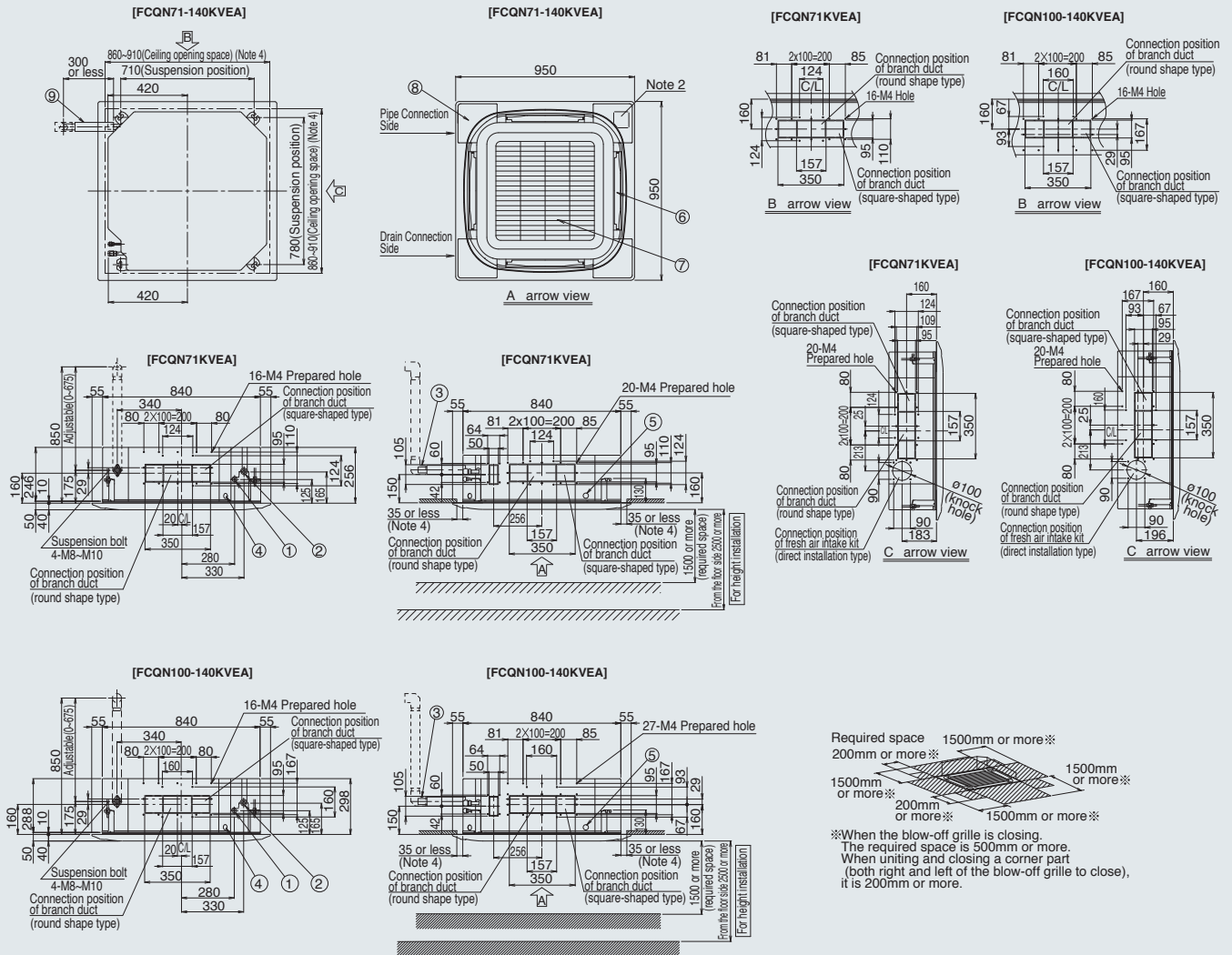

- Notes:
- ¹ Sticking location for manufacturer's label
manufacturer's label for indoor unit:
Suction grille inner side's electric components box's lid surface
manufacturer's label for decoration panel :
Decoration panel's corner decoration cover inner surface
 - ² In case of using wireless remote controller, this position will be a signal receiver. Refer to the drawing of wireless remote controller in detail.
 - ³ When the temperature and humidity in the ceiling exceed 30°C and RH 80% or the fresh air is inducted into the ceiling or the unit continues 24 hour operation, an additional insulation (thickness 10mm or more of glasswool or polyethylene form) is required.
 - ⁴ Though the installation is acceptable up to maximum of 910mm square ceiling opening, keep the clearance of 35mm or less between the indoor unit and the ceiling opening so that the panel overlap allowance can be ensured.
 - ⁵ Please do not place the thing been damp and troubled under an indoor unit.
When the case where humidity is 80% or more, and the drain outlet are choked up and the air filter are dirty, dew may fall.

- ① Liquid pipe connection
- ② Gas pipe connection
- ③ Drain pipe connection
- ④ Power-source wiring and a unit wiring connection
- ⑤ Connection wiring / remote control wiring connection
- ⑥ Air-outlet
- ⑦ Suction grille
- ⑧ Corner decoration cover
- ⑨ Drain hose (accessory)

DIMENSIONS (Unit: mm)

OUTDOOR UNIT // RQ71LV1A

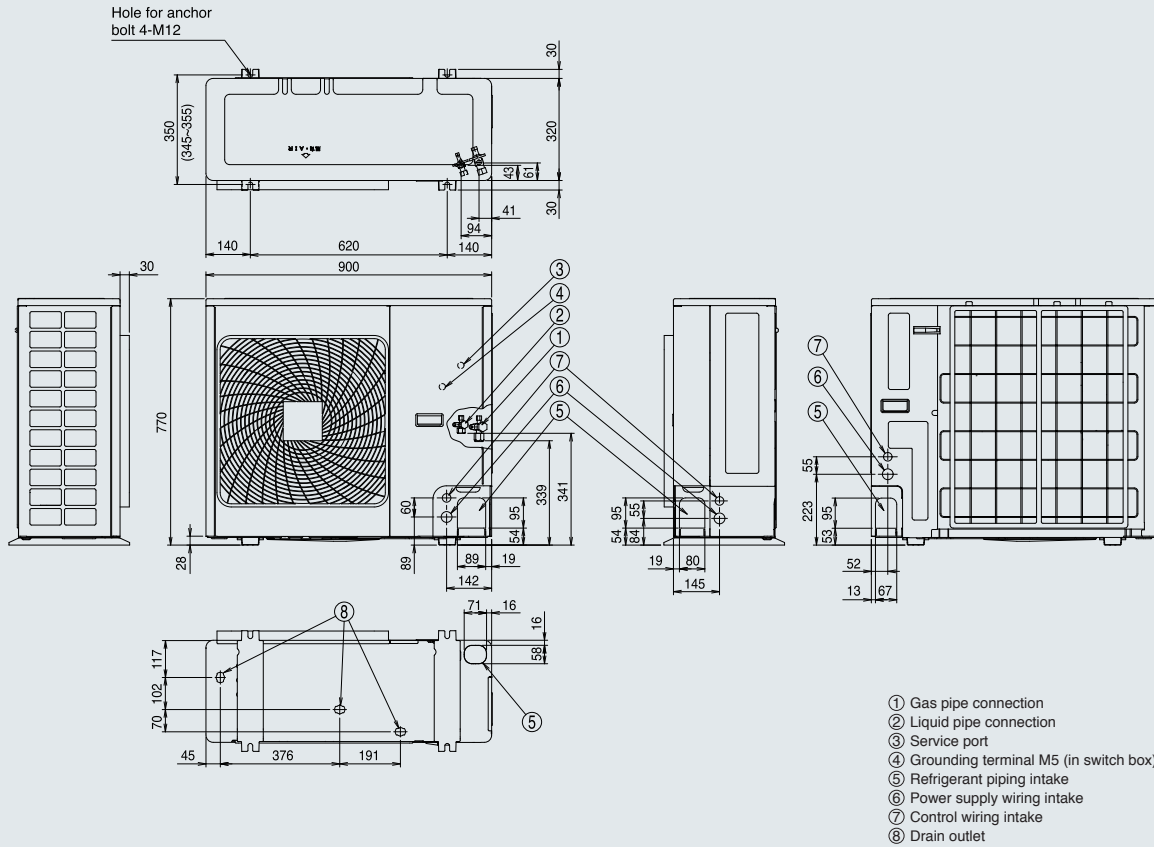

OUTDOOR UNIT // RQ100LV1A, 125LV1A, 140LV1A

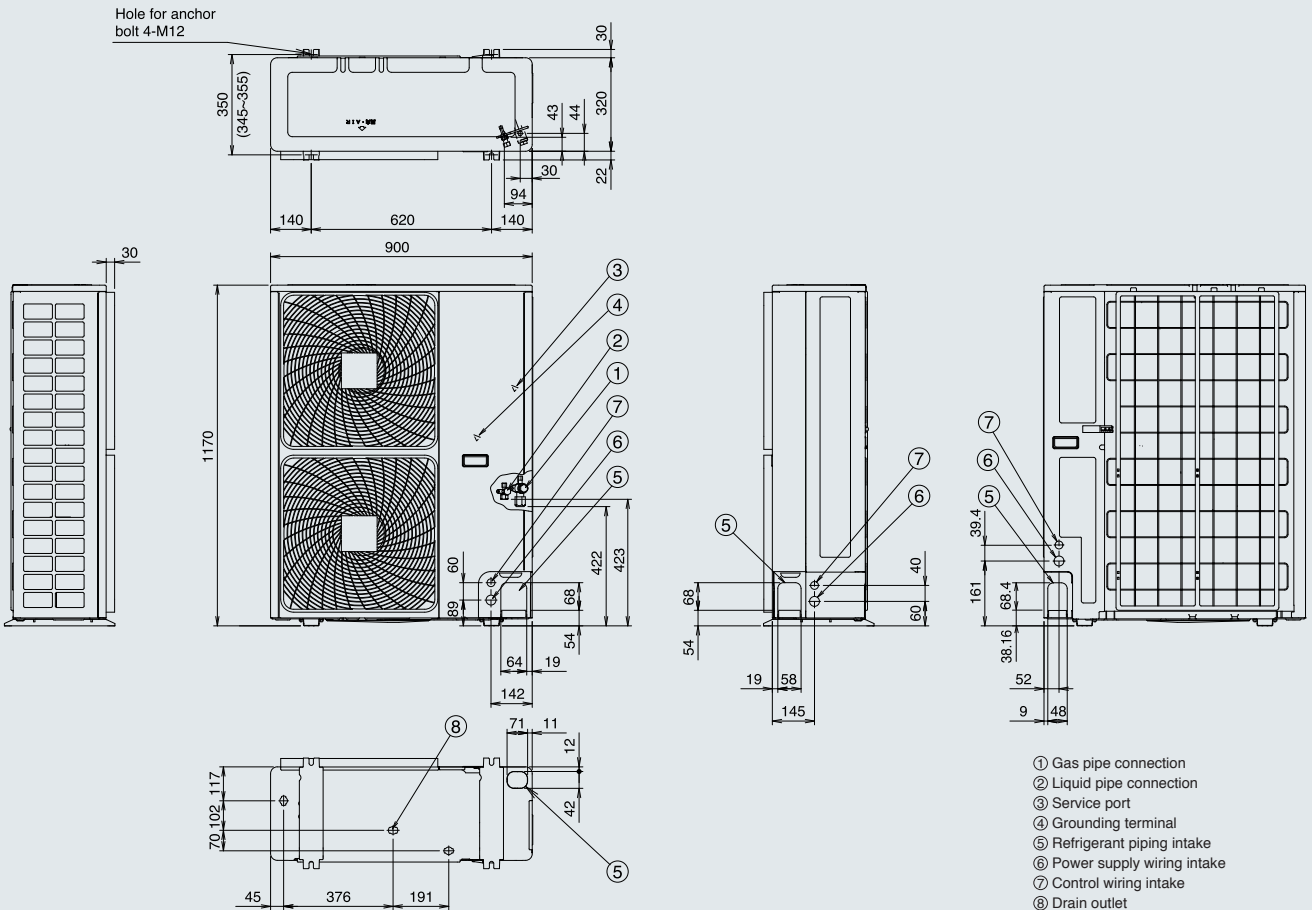

REMOTE CONTROLLER

《Wireless type》

Remote controller dimensions

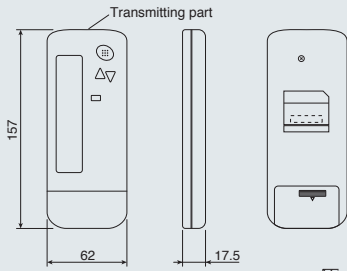

Remote controller holder installation procedure
<installation to wall surface>

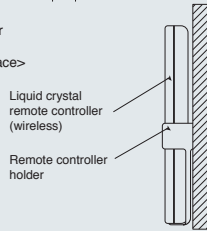

CEILING MOUNTED CASSETTE TYPE

Receiver installation procedure

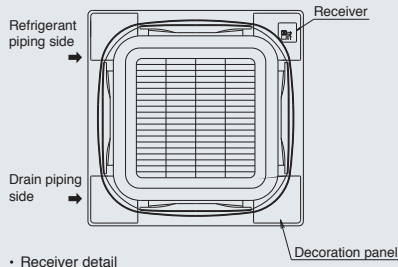

Receiver detail



《Wired type》

Remote controller dimensions

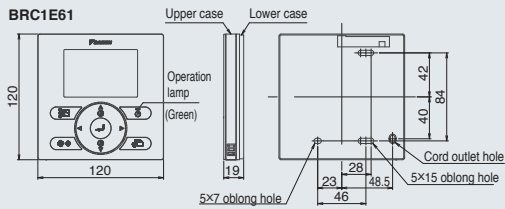

Installation method

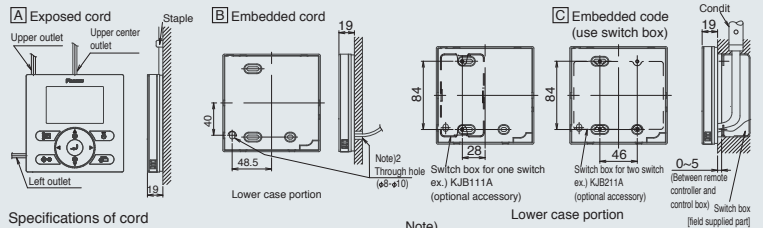

Specifications of cord

Type	*	Vinyl cord with sheath or cable (insulated thickness: 1mm or more)
Size		0.75~1.25 mm ²
Total length		500 m

Note

1. Remote controller cord and staple are not attached. They are field supplied parts.
2. If the hole size is too large or the location is not proper, the hole may come out from the remote controller.

Example of installation service space for outdoor unit

■ For RQ71-140LV1A

The values represent the case for the RQ100-140LV1A.
The dimensions in () are for the RQ71LV1A (The unit values is mm.)

1) When there is an obstruction on the inlet side

1) When the overhead space is open

1. For single unit installation

When there is an obstruction only on the inlet side

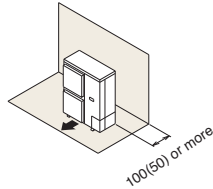

When there are obstructions on both sides

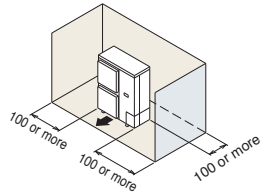

2. For multiple units installation (more than two units)

When there are obstructions on both sides

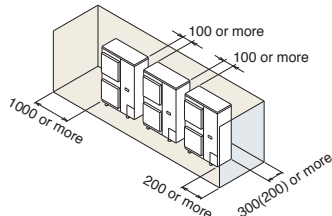

2) When there is an obstruction in the overhead space

1. For single unit installation

When there is an obstruction on the inlet side

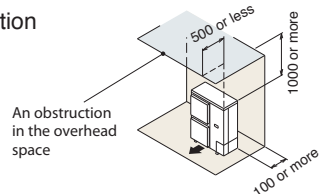

When there are obstructions on the inlet side and both sides

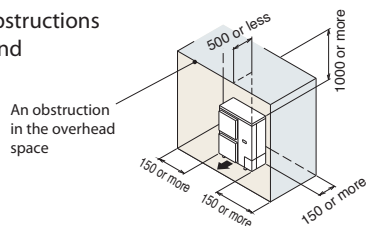

2. For multiple units installation (more than two units)

When there are obstructions on the inlet side and both sides

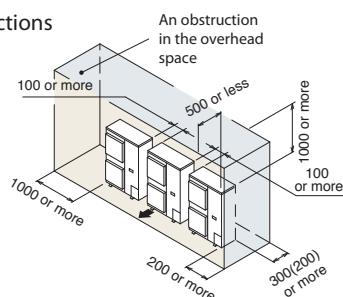

2) When there is an obstruction on the outlet side

1) When the overhead space is open

1. For single unit installation

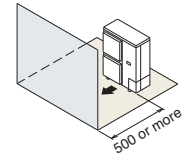

2. For multiple units installation (more than two units)

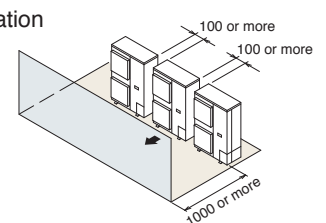

2) When there is an obstruction in the overhead space

1. For single unit installation

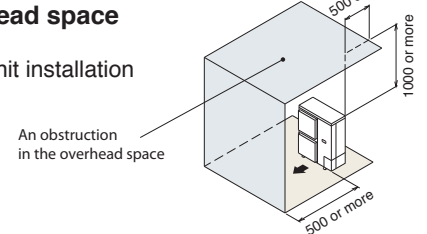

2. For multiple units installation (more than two units)

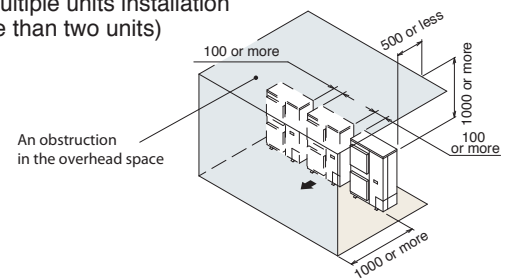

3) When there are obstructions on both the inlet and outlet sides

(When the obstruction on the outlet side is higher than the unit itself)

1) When the overhead space is open

(There is no limit to the height of the obstruction on the outlet side.)

1. For single unit installation

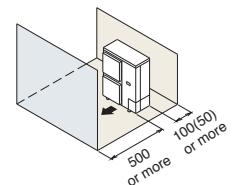

2. For multiple units installation (more than two units)

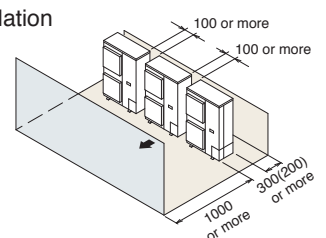

Note : As for other patterns of installation, please refer to Installation manual or Engineering Data Book.

Warning



- Daikin products are manufactured for export to numerous countries throughout the world. Prior to purchase, please confirm with your local authorised importer, distributor and/or retailer whether this product conforms to the applicable standards, and is suitable for use, in the region where the product will be used. This statement does not purport to exclude, restrict or modify the application of any local legislation.
 - Ask a qualified installer or contractor to install this product. Do not try to install the product yourself. Improper installation can result in water or refrigerant leakage, electrical shock, fire or explosion and may have resultant impacts on warranty.
 - Use only those parts and accessories supplied or specified by Daikin. Ask a qualified installer or contractor to install those parts and accessories. Use of unauthorised parts and accessories or improper installation of parts and accessories can result in water or refrigerant leakage, electrical shock, fire or explosion.
 - Read the User's Manual carefully before using this product. The User's Manual provides important safety instructions and warnings. Be sure to follow these instructions and warnings.
- If you have any enquiries, please contact your local importer, distributor and/or retailer.

Cautions on product corrosion

1. Air conditioners should not be installed in areas where corrosive gases, such as acid gas or alkaline gas, are produced.
2. If the outdoor unit is to be installed close to the sea, direct exposure to sea breeze should be avoided. If you need to install the outdoor unit close to the sea, contact your local distributor.



JMI-0107

Organization:
DAIKIN INDUSTRIES, LTD.
AIR CONDITIONING MANUFACTURING
DIVISION

Scope of Registration:
THE DESIGN/DEVELOPMENT AND
MANUFACTURE OF COMMERCIAL AIR
CONDITIONING, HEATING, COOLING,
REFRIGERATING EQUIPMENT, HEATING
EQUIPMENT, RESIDENTIAL AIR
CONDITIONING EQUIPMENT, HEAT
RECLAIM VENTILATION, AIR CLEANING
EQUIPMENT, COMPRESSORS AND VALVES.



JQA-1452

Organization:
DAIKIN INDUSTRIES
(THAILAND) LTD.

Scope of Registration:
THE DESIGN/DEVELOPMENT
AND MANUFACTURE OF AIR
CONDITIONERS AND THE
COMPONENTS INCLUDING
COMPRESSORS USED FOR
THEM



Quality
ISO 9001

Daikin Australia
Pty Limited (ISO9001)
OEC23256 May 31, 2006
Sydney, Brisbane, Adelaide,
Melbourne, Newcastle,
Townsville, Perth, Auckland



EC99J2044

All of the Daikin
Group's business
facilities and
subsidiaries in Japan
are certified under the
ISO 14001
international standard
for environment
management.



Environment
ISO 14001

Daikin Australia
Pty Limited (ISO14001)
CEM20437 October 27, 2006
Sydney, Brisbane, Melbourne,
Adelaide

Dealer

DAIKIN INDUSTRIES, LTD.

Head Office:
Umeda Center Bldg., 2-4-12, Nakazaki-Nishi,
Kita-ku, Osaka, 530-8323 Japan

Tokyo Office:
JR Shinagawa East Bldg., 2-18-1, Konan,
Minato-ku, Tokyo, 108-0075 Japan

http://www.daikin.com/global_ac/

©All rights reserved Printed in Australia 04/12 SS